

848H SPECIFICATIONS >>>



OPERATING WEIGHT 16870 KG

ENGINE

YuChai 6 cylinder, CRDi, Turbocharged, Intercooled Engine Designed and Developed for LiuGong's Wheel Loader.

Manufacturer	Yuchai
Model	YCK09220-B460
Emmission Regulation	CEV Stage IV
Gross Power	220 HP (162 kW) @ 2000 rpm
Peak Torque	1100 Nm @ 1400 rpm
Displacement	9.41 L
Aspiration	Turbocharged, Intercooled
Number of Cylinders	6

BUCKET RANGES

Heavy duty big buckets are designed to offer high output, breakout force and fill factor.

Light Material Bucket	4.3 m ³
General Purpose Bucket	2.8 m ³
Rock Bucket	2.0 m ³

TRANSMISSION

Make	LiuGong
Transmission Type	Powershift
Torque Converter	Twin Turbine, Four Members
Number of Speed	Forward 2 / Reverse 1
Forward Speed F1 / F2	13 / 40 Km/hr
Reverse: R1	17 Km/hr

AXLES

Make	LiuGong
Type	Dry Type Planetary Hub Reduction
Axle Oscillation	Front Fixed and Rear ±12°

TIRES

Tire Size	23.5-25-16PR
-----------	--------------

BRAKE SYSTEM

Service Brake	4 Wheel applied air over hydraulic with independent circuit for front & rear axle
Parking Brake	Drum Brake Mechanical Actuation
Secondary Brake	Manually Applied on Low Pressure

HYDRAULIC SYSTEM

Efficient and reliable hydraulics having independent pumps for work implement and steering system generating flow for optimum performance.

Main Pump Type	Gear Pump
Main Relief Pressure	17 Mpa
Main Pump Flow	332 Lpm
Cycle Time	10.3 Sec
Control	Single Pilot Lever
Cylinders	Double Acting Cylinder

STEERING SYSTEM

Steering Type	Articulation
Pump Type	Gear Pump
Steering Relief Pressure	16.5 Mpa
Steering System flow	124 LPM
Maximum Articulation Angle	± 38°

CABIN

Ergonomically designed AC cabin has 4 working cab lights, wipers, adjustable seat, single joystick operated hydraulics with hand rest, music system, cup holder, large instrument panel for - (DEF level gauge, fuel level gauge, turn indicators, engine tachometer, engine coolant temperature gauge, transmission oil temperature gauge, various status and warning indicators), removable floor mat, laminated front glass, 02 external side view mirrors.

AIS160 Compliant for safety and performance.

ELECTRICAL SYSTEM

System Voltage	24 V
Battery	12 V x 2

LOADER PERFORMANCE WITH STANDARD BUCKET 2.8 M³

Tipping Load- Straight	12875 kg
Tipping Load- Full Turn	10300 kg
Bucket Breakout Force	167 kN
A-Hinge Pin Height, Fully Raised	4114 mm
B-Dumping Height, Fully Raised	3081 mm
C-Dumping Reach, Fully Raised	1125 mm
D-Max. Digging Depth	50 mm
E-Min. Ground Clearance	423 mm
G-Wheel Base	3250 mm
H-Overall Height (Top of Cab)	3500 mm
J-Tread Width	2150 mm
K-Overall Width (Outside of Wheel)	2740 mm
L-Overall Length	8146 mm
W-Overall Width (Outside of Bucket)	2970 mm
P-Departure Angle	30°
S1-Bucket Rollback at Ground Level	43°
S2-Bucket Rollback at Carry	48°
S3-Bucket Roll Back at Maximum	63°
S4-Maximum Dump Angle at Full Height	45°
R1-Turning Radius (Outside of Bucket)	7000 mm
R2-Turning Radius (Outside of Rear Wheel)	6000 mm

SERVICE CAPACITIES

Fuel Tank	280 L
Engine Oil	32 L
Adblue	25 L
Cooling System	50 L
Transmission & Torque Converter	35 L
Hydraulic Tank	225 L
Axle Oil Each	33 L

OPTIONAL

- Certified ROPS/FOPS Cabin
- DGMS KIT
- Automatic Centralized Lubrication
- Automatic Fire Suppression System
- Rear View Camera
- Rotary Beacon
- Cabin Guard
- GPS (LiuGong i-Link)

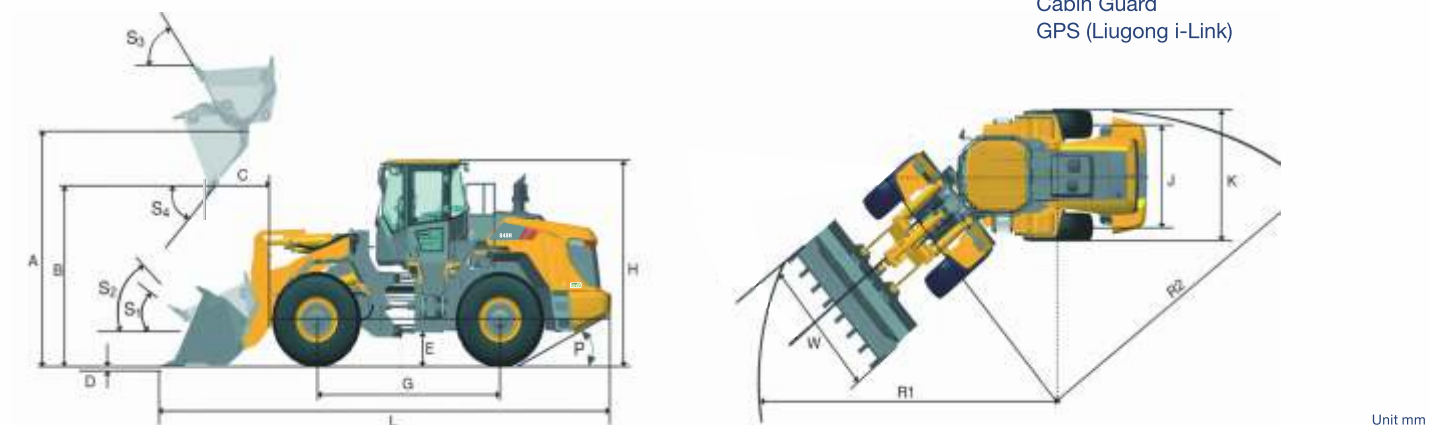

Unit mm

All parameters within (±) 2.5% of the specified values. Specification is subject to change without notice. LiuGong standard and optional equipment may vary from region to region. Please consult your LiuGong dealer for information specific to your area.

Corporate office
LiuGong India Pvt. Ltd.
101, Okhla Industrial Estate, Phase III
New Delhi- 110020
Tel.: 011- 47272200
www.liugong.com
india@liugong.com

Plant Address:
Plot No. 163, Industrial Area,
Sector - III, Pithampur,
Dist. - Dhar, Madhya Pradesh - 454774
Tel.: 07292-416700

Specifications and designs are subject to change without notice. Machines shown may include optional equipment.

Mera LiuGong Mera Vishwas
1800 1033 852

12/2022 LIPL

Engine	Yuchai
Gross Power	220 HP (162 kW)
Operating Weight	16,870 kg
Payload Capacity	4500 Kg
Standard Bucket	2.8 m ³

848H WHEEL LOADER

TOUGH WORLD. TOUGH EQUIPMENT.

REDEFINING PERFORMANCE

- Unmatchable heavyweight champion with class defining payload of 4500kg.
- Powered by a mighty 9.4L, 6 cylinders, turbocharged, intercooled, HPCRDi engine.
- LiuGong's own powertrain produces high traction force, helps to move more.
- High dump clearance and reach for easy centre filling (even for extended body trucks)



4500KG
Best in class payload

COMFORT BOOSTS PRODUCTIVITY

- Wide spacious air conditioned cabin.
- Easy and safe accessibility (in | out)
- All around visibility.
- Precise responsive single pilot lever Joystic.
- Smooth responsive foot pedals.



MAXIMIZING UPTIME

- **Durable by design**, uncompromised long operating hours.
- **Proactive monitoring** empowered by LiuGong's Smart **i-Link** telematics.
- **Maintenance made** easier with increased service accessibility.
- **Here to serve**, Make in India with wide after sales network.



EFFICIENCY BOOSTERS

- Low speed constant high torque engine, designed precisely for LiuGong's wheel loaders with fuel efficiency in mind.
- LiuGong's inhouse powertrain components ensure most efficient power transmission from engine to wheels.
- Torque converter with twin turbine technology for maximum traction with high fuel efficiency.
- LiuGong's inhouse hydraulic components fine tuned for faster response and efficient energy management.
- Easy Fill | High Fillfactor (**EFHF**) bucket penetrates easily in material heap saving hydraulic energy and fuel.
- LiuGong's i-link telematics provides fuel saving insights based on work pattern.



Power of 6 Cylinders



Turbocharged-Intercooled



HPCRDi



LiuGong's Powertrain

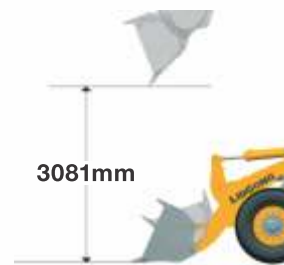

3081mm
High Dump Clearance

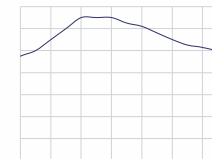

— Torque (Nm)
LSCHT Engine



Efficient Powershift



Twin Turbine
Torque Converter



LiuGong i-Link



H Series
Others
EFHF Buckets

RELIABILITY COMMITMENT

- CE special engine for continuous long operating hours in dynamic duty cycles.
- 3 Stage fuel filtration and 3 stage air filtration keeps engine healthy and safe.
- Optimum cooling system to prevent overheating of components even in extreme hot weathers and long operating hours.
- LiuGong's heavy duty powertrain, enhanced overtime with V.O.C and true wheel loader experience.
- **FEA/CAE** approved heavy duty robust structures made inhouse with best Indian steel grades.
- Timetested durable hydraulic components
- Extended counterweight for collision protection of engine hood.
- HD buckets with wear resistant special grade materials.



HD Z-Bar Mechanism



Engine



LiuGong's Heavy Duty Axles Transmission & Hydraulic Component



Hood Collision Protection

FEA / CAE Approved Robust Chassis & Structures

