



BUILT IN BHARAT

Excellence Series

Engine	Cummins 6BTAA5.9
Gross Power	148 hp @ 2,000 rpm
Bucket Capacity	0.45 m ³
Digging Depth	15,124 mm
Operating Weight	26,000 kg
Cabin	Air Conditioned

925E XLR EXCAVATOR

TOUGH WORLD. TOUGH EQUIPMENT.

925E XLR SPECIFICATIONS >>>



ENGINE

Make	CUMMINS
Engine Model	6BTAA5.9
Gross Power	148 hp @ 2,000 rpm
Peak Torque	626 N·m @ 1,300 rpm
Displacement	5.9 L
Aspiration	Turbocharged, CAC

HYDRAULIC SYSTEM

Main Pump Flow	2 x 224 LPM
Pilot Pump Flow	19 LPM
Relief Valve Setting	
Implementation	34.3/37.3 MPa
Travel Circuit	34.3 MPa
Swing Circuit	28.5 MPa
Pilot Circuit	3.9 MPa

SWING SYSTEM

Swing Speed	12 rpm
Swing Torque	68591 N·m
Swing Motor	Axial Piston Motor
Swing Reduction	Planetary Gear
Swing Bearing	Lubrication Grease Bathed

BUCKETS

Bucket	0.45 m ³
--------	---------------------

UNDERCARRIAGE

Center Frame	X-Plate
Track Frame	Box Type
Track Shoe Each Side	49
Shoe Width, Triple Grouser	800 mm
Bottom Rollers Each Side	8
Top Rollers Each Side	2

DRIVE SYSTEM

Travel Speed (High/Low)	(5.1/3.0) Km/h
Gradeability	(35°) 70%
Max. Drawbar Pull	212 kN
Drive Motor	Axial Piston Motor
Drive Reduction	Planetary Gear

SERVICE CAPACITIES

Fuel Tank	420 L
Engine Oil	20 L
Final Drive	3.4 Lx2
Swing Drive	4.6 L
Hydraulic Tank	180 L

ELECTRICAL SYSTEM

Voltage	24 V
Battery	12 V, 100Ah x2
Working Lights	5

OPERATING WEIGHT

Operating Weight	26,000 kg
------------------	-----------

WORKING RANGE

Boom Length	10,350 mm
Arm Length	8,000 mm
A Max. Digging Reach	18,361 mm
B Max. Digging Reach on Ground	18,282 mm
C Max. Digging Depth	15,124 mm
D Max. Cutting Height	14,726 mm
E Max. Dumping Height	12,606 mm
F Min. Front Swing Radius	4,539 mm

WORKING DIMENSIONS (Reference Bucket - 0.45 m³)

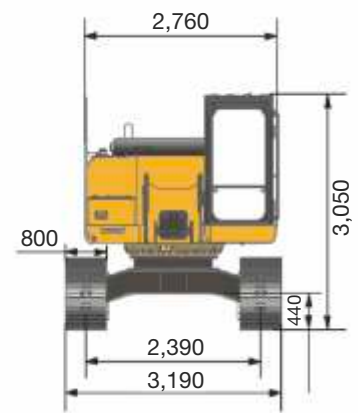
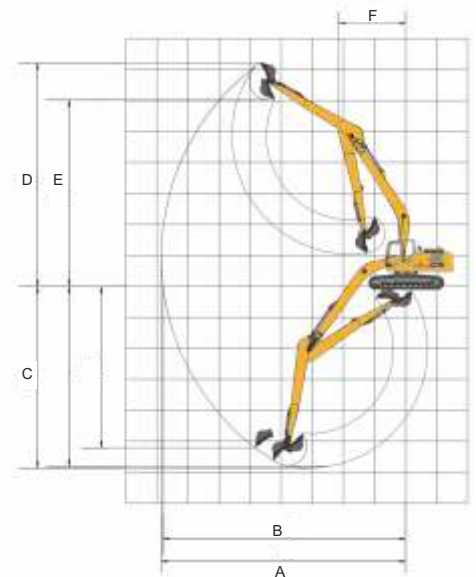

LiuGong standard and optional equipment may vary from region to region. Please consult your LiuGong dealer for information specific to your area.

Corporate office
LiuGong India Pvt. Ltd.
 82, Okhla Industrial Estate, Phase III
 New Delhi- 110020
 Tel.: 011- 47272200
 www.liugong.com
 india@liugong.com

Plant Address:
 Plot No. 163, Industrial Area,
 Sector - III, Pithampur,
 Dist. - Dhar, Madhya Pradesh - 454774
 Tel.: 07292-416700

Mera LiuGong Mera Vishwas
1800 1033 852

Specifications and designs are subject to change without notice. Machines shown may include optional equipment.